

A QUICK "HOW-TO" REPAIR GUIDE

SEAT FRAME REPLACEMENT

PARTS REQUIRED: SEAT FRAME ASSEMBLY (#5A)
SEAT ROD/WASHERS (#5B)
SEAT HINGES/SCREWS (saved from chair)

TOOLS REQUIRED: ELECTRIC DRILL
BITS 7/64"
PHILLIPS SCREWDRIVER
HACKSAW
HAMMER
STEEL PLATE
RIVET CLINCHER TOOL

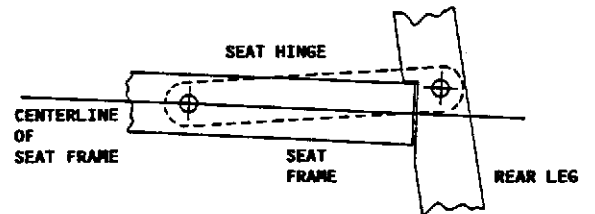

REMOVE SEAT PAD.

With PHILLIPS SCREWDRIVER, remove the FRONT SEAT HINGE SCREW from both LEFT and RIGHT sides of SEAT FRAME. Save SCREWS.

With HACKSAW, cut through the SEAT ROD, remove this through the LEFT and RIGHT sides of the FRONT LEGS. Save WASHERS.

Insert the new SEAT ROD through one side of either FRONT LEG. When end is clear, replace the WASHERS from that side. Insert the SEAT ROD through the SEAT FRAME ASSEMBLY until the end exits the other side of the SEAT FRAME ASSEMBLY. Replace the WASHERS from that side. Continue inserting SEAT ROD through the other FRONT LEG.

With the STEEL PLATE on a sturdy bench, position the chair on its side so that the HEAD of the SEAT ROD is centered on the PLATE. Position the RIVET CLINCHER TOOL so that the center dimple is in the open end of the SEAT ROD. Strike several blows with the HAMMER. When this has been done correctly, you will see a smoothly rolled shoulder on the end of the SEAT ROD.

Place the chair in an upright position on the bench. Using a strap or stiff wire retainer attached over the FRONT and REAR SPREADERS, position the SEAT FRAME ASSEMBLY so that the UPPER REAR EDGE IS RESTING TIGHT AGAINST THE NOTCHED PORTION OF THE REAR LEGS!!! *****LOOK AT AN ASSEMBLED CHAIR*****

*****USE THE STRAP OR STIFF WIRE RETAINER TO HOLD THE CHAIR TOGETHER AND KEEP THE UPPER, REAR EDGE OF THE SEAT FRAME IN THAT POSITION DURING THE NEXT STEP*** THIS IS CRITICALLY IMPORTANT!!!!!!!!!!**

Position the SEAT HINGE as shown in the drawing above and MARK THE CENTER FOR THE FRONT SCREW through the hole at the FRONT of each SEAT HINGE.

With the ELECTRIC DRILL and 7/64" BIT, drill new holes in the SEAT FRAME on your marks.

With a PHILLIPS SCREWDRIVER, replace the SEAT HINGE SCREWS and TIGHTEN FIRMLY.

Remove the strap/retainer wire. The chair is repaired.

REAR LEG ASSEMBLY REPLACEMENT

PARTS REQUIRED: REAR LEG ASSEMBLY
REAR RIVETS/WASHERS (#8)
SEAT HINGES/SCREWS (saved from chair)

TOOLS REQUIRED: ELECTRIC DRILL
BITS 1/4" and 7/64"
PHILLIPS SCREWDRIVER
HAMMER
STEEL PLATE
RIVET CLINCHER TOOL

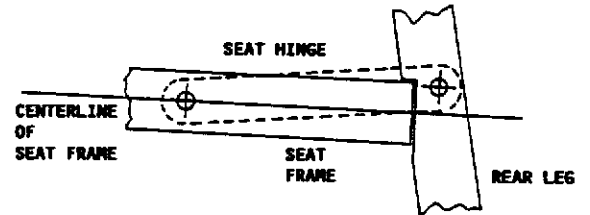

With PHILLIPS SCREWDRIVER, remove the REAR SEAT HINGE SCREWS from both LEFT and RIGHT sides of REAR LEGS. Save SCREWS.

With the ELECTRIC DRILL and 1/4" BIT, drill off the rolled shoulder of the REAR RIVETS on the chair. Push out RIVETS and save WASHERS.

Starting with either side, insert new REAR RIVET through outside of FRONT LEG until the end is clear, replace the WASHERS from that side and continue insertion of RIVET until the end comes through the REAR LEG. Repeat this for the other side now.

With STEEL PLATE on a sturdy bench, position the chair on its side so that the HEAD of the REAR RIVET is centered on the PLATE. Position the RIVET CLINCHER TOOL so that the center dimple is in the open end of the REAR RIVET. Strike several blows with the HAMMER. When this has been done correctly, you will see a smoothly rolled shoulder on the end of the REAR RIVET. Repeat this operation for the other side.

Place the chair in an upright position on the bench. Using a strap or stiff wire retainer attached over the FRONT and REAR SPREADERS, position the SEAT FRAME ASSEMBLY so that the UPPER REAR EDGE IS RESTING TIGHT AGAINST THE NOTCHED PORTION OF THE REAR LEGS!!! *****LOOK AT AN ASSEMBLED CHAIR*****

*****USE THE STRAP OR STIFF WIRE RETAINER TO HOLD THE CHAIR TOGETHER AND KEEP THE UPPER REAR EDGE OF THE SEAT FRAME IN THAT POSITION DURING THE NEXT STEP*** THIS IS CRITICALLY IMPORTANT!!!!!!!!!!**

Position the SEAT HINGE as shown in the drawing above and MARK THE CENTER FOR THE REAR SCREW through the hole at the REAR of each SEAT HINGE.

With the ELECTRIC DRILL and 7/64" BIT, drill new holes in the SEAT FRAME on your marks.

With a PHILLIPS SCREWDRIVER, replace the SEAT HINGE SCREWS and TIGHTEN FIRMLY.

Remove the strap/retainer wire. The chair is repaired.

MAIN FRAME ASSEMBLY REPLACEMENT

PARTS REQUIRED: MAIN FRAME ASSEMBLY
SEAT ROD/WASHERS (#5B)
REAR RIVETS/WASHERS (#8)
SEAT HINGES/SCREWS (saved from chair)

TOOLS REQUIRED: ELECTRIC DRILL
BITS 1/4"
PHILLIPS SCREWDRIVER
HAMMER
STEEL PLATE
RIVET CLINCHER TOOL
HACKSAW

REPAIR OF THIS ASSEMBLY IS A COMBINATION OF PAGES -1- AND -2-

REMOVE SEAT PAD.

With PHILLIPS SCREWDRIVER, remove the FRONT and REAR SEAT HINGE SCREWS from both LEFT and RIGHT sides of REAR LEGS and SEAT FRAME. Save SCREWS.

With the ELECTRIC DRILL and 1/4" BIT, drill off the rolled shoulders of the REAR RIVETS, push them through and remove the REAR LEG ASSEMBLY.

With the HACKSAW, cut through the SEAT ROD and push this out through the LEFT and RIGHT sides of the FRONT LEGS.

Using the new MAIN FRAME ASSEMBLY, insert new REAR RIVETS as per instructions on page "2". With the RIVET CLINCHER, set the rivets and attach the SEAT HINGES to the REAR LEGS as previously instructed.

Now install the SEAT FRAME ASSEMBLY as outlined on page "1" and set the SEAT ROD with the RIVET CLINCHER TOOL.

USE A STRAP OR STIFF WIRE RETAINER TO HOLD THE CHAIR TOGETHER AND KEEP THE UPPER, REAR EDGE OF THE SEAT FRAME TIGHT AGAINST THE NOTCHED PORTION OF THE REAR LEGS THIS IS CRITICALLY IMPORTANT

With the PHILLIPS SCREWDRIVER, attach the SEAT HINGE to the SEAT FRAME ASSEMBLY.

Remove the strap/retainer wire. The chair is repaired.

If you wish to, you should remove ALL SALVAGEABLE PARTS from any and all ASSEMBLIES. These may be of use at a later date should you elect to repair a part of an ASSEMBLY.

WHEN YOU NEED TO REPAIR OUR "210-SERIES" CHAIRS

ALL YOU NEED ARE THESE SIMPLE TOOLS

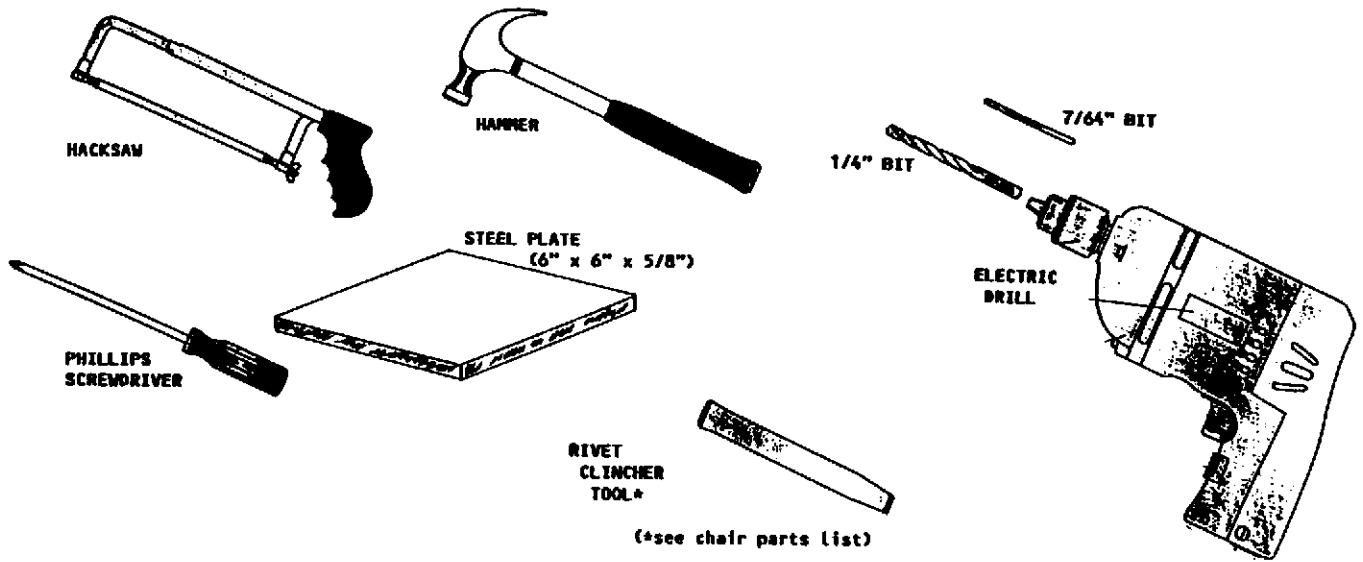

. . . . AND OUR "REPAIR ASSEMBLIES"

